

HE001.1 AHKC-EKB Series Open Hall Current Sensor V1.0

1. Product Introduction

It is insulative between the primary and secondary grade of AHKC-EKB series current sensor which can be used for measuring direct current, alternating current and pulse current.

2. Technical Parameters and Overall Dimensions

Parameters	Index
Rated Input Current	0~±(50-1000)A
Rated Output Voltage	±5V/±4V
Accuracy Class	1.0
Power Voltage	DC±15V (allowable fluctuation±20%)
Zero Offset Voltage	±20mV
Offset Voltage Drift	≤±1.0mV/°C
Linearity	≤0.2%FS
Response Time	≤5us
Bandwidth	0~20kHz
Isolation Voltage	3.5kV/50Hz/1min
Operating Temperature	-40°C ~ 85°C
Storage Temperature	-40°C ~ 85°C
Consumption	≤0.5W

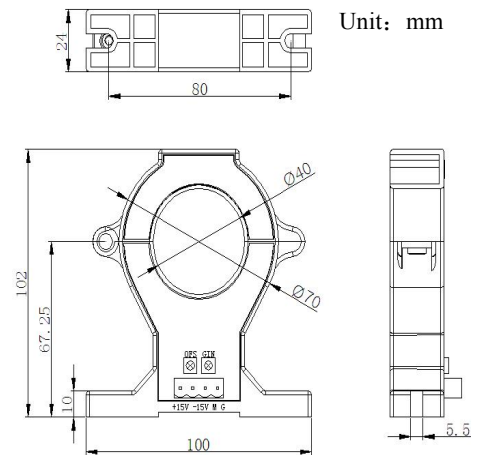

3. Installation Method

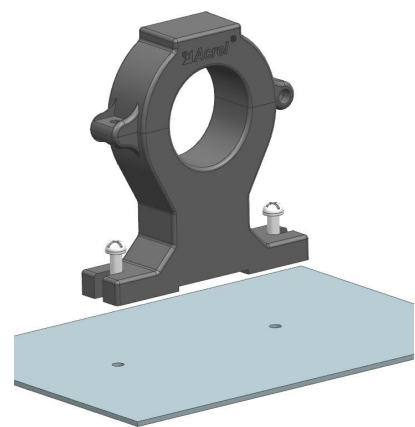
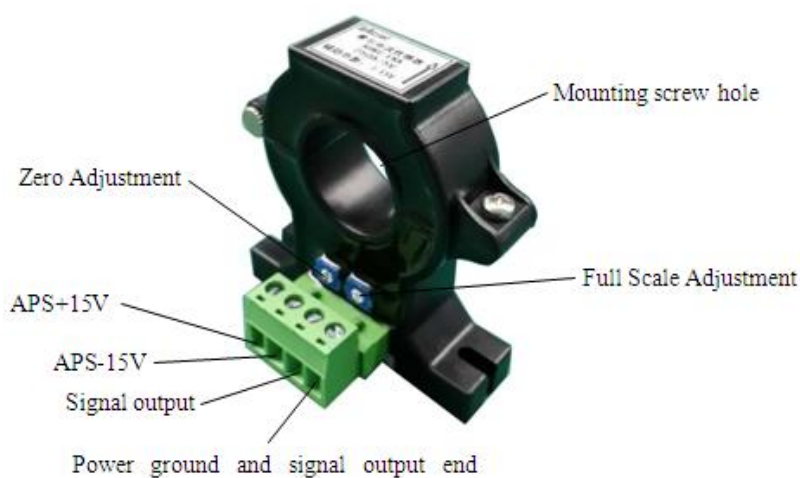

Base Plate Screw M3 (gasket)
Installation

4. Mode of Connection

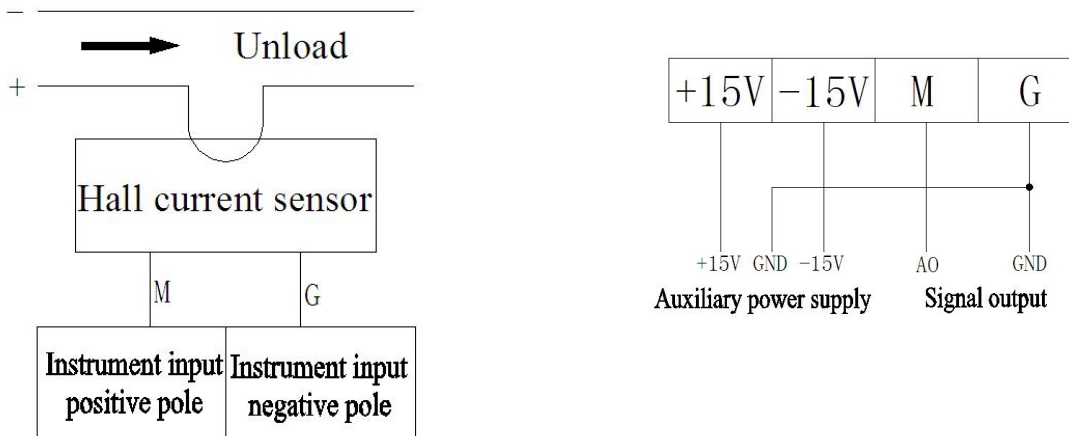

+15V — power supply +15V

-15V — power supply -15V (Note that power positive and negative poles cannot be inversely connected.)

M — signal output end positive pole

G — power ground and signal output end negative pole

Note: The specific wiring is subject to the terminal no. of object shell.

5. Precautions

1. When the Hall sensor is used, attention must be paid to the coupling between the primary side coil and assistant side coil in order to get better dynamic characteristics and sensitivity, single conductor that should cram the thread hole of Hall sensor module completely is proposed to use.

2. When the Hall sensor is used, the best measuring accuracy can be got under rated input current value. When the measured current is much less than the rated value, the primary side can use multi-turns if want to obtain the best accuracy, that is $I_p N_p = \text{rated ampere-turns}$. In addition, the temperature of the primary side feeder line cannot be more than 80°C .

3. When the Hall current sensor is working normally, the auxiliary power supply cannot be more than $\pm 20\%$ of calibration value.

4. The Hall Current sensor is strictly prohibited to be fallen from high place ($\geq 1\text{m}$) during installation and use.

5. Zero and full scale regulator potentiometer can not be adjusted.

6. Auxiliary power supply is required to be deployed voluntarily.

7. Power positive and negative poles cannot be inversely connected.

6. Order Sample

Sample 1 AHKC-EKB Hall current sensor

Auxiliary power supply: DC $\pm 15\text{V}$

Input: 200A

Output: 5V

Accuracy: Grade 1