

新能源电动汽车传感器 AHKC-HAB100...900

$I_p=100\text{...}900\text{A}$



产品特点 Products Features

安装方便
Easy mounting
体积小，节省空间
Small size and space saving
无插入损耗
No insertion losses
抗干扰能力强
High immunity to external interference

应用领域 Applications

电动汽车
EV Auto
交流变速驱动器
AC variable speed drives
直流电机驱动静态转换器
Static converters for DC motor drives
通讯电源
Battery supplied applications
不间断电源 (UPS)
Uninterruptible Power Supplies

注意 Remarks

错误的接线可能导致传感器损坏。
The false wiring may result in the damage of the sensor.
 I_p 方向与产品箭头方向一致时，输出电压为正极。
VOUT is positive when I_p flows in the direction of the arrow.
当初级导体完全充满初级孔径时动态表现 (di/dt 和响应时间) 为最佳效果。
Dynamic performances (di/dt and response time) are best with a single bar completely filling the primary hole.
初级导体的温度不应超过 100°C 。
Temperature of the primary conductor should not exceed 100°C .
这是一个标准的产品，需要其他规格 (测量电流、电源电压、输出电压、连接器、转换比率等) 请联系我们。
This is a standard model. For different versions (I_p , supply voltages, output voltages, connection of secondary, turns ratios...), please contact us.

机械尺寸 Mechanical dimension

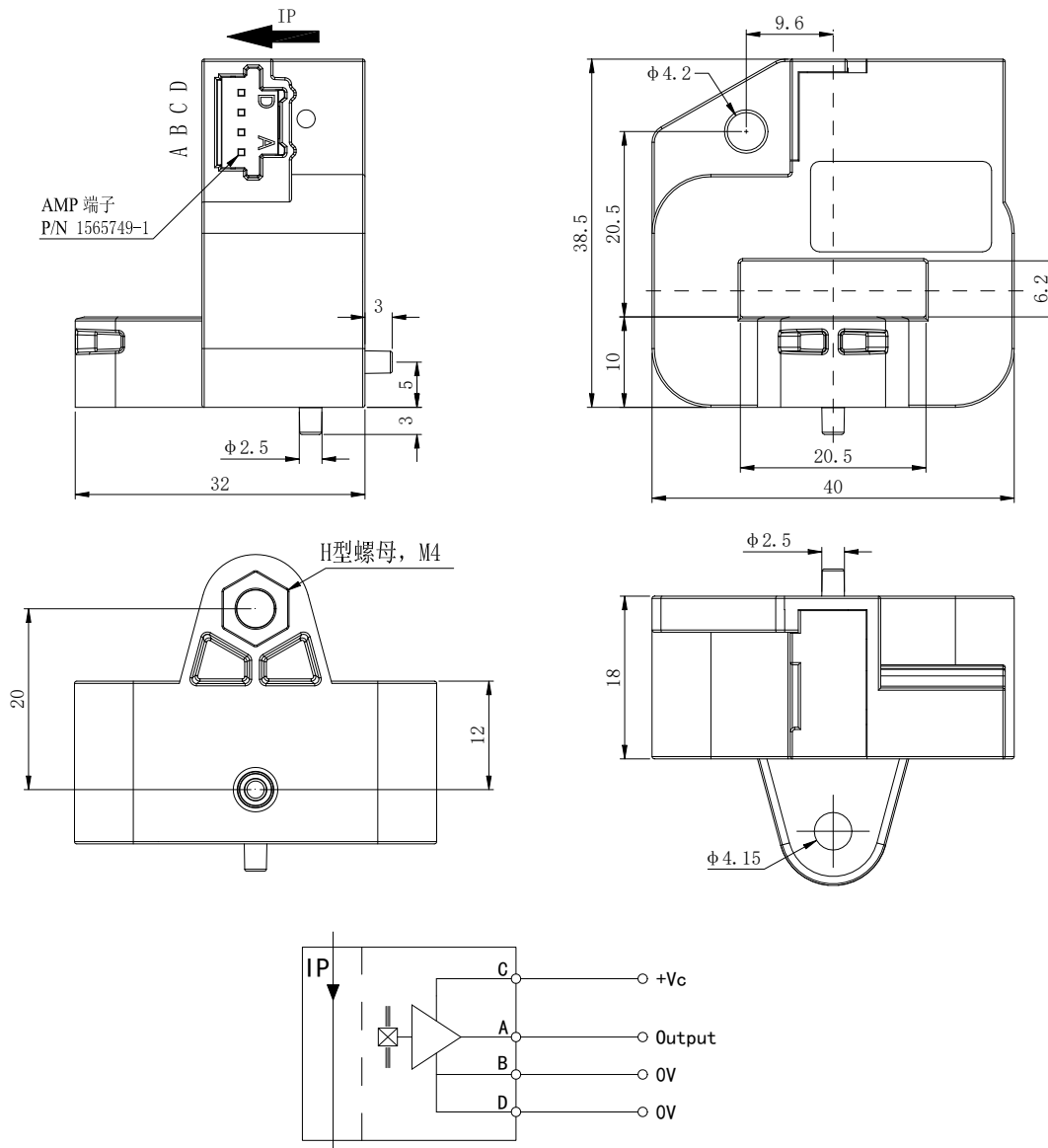

机械特性 Mechanical characteristics

一般公差	
General tolerance	$\pm 0.5 \text{ mm}$
其它公差执行	
Other tolerance execution	GB/T 1804-2000-M
固定孔尺寸	$\Phi 4.2\text{mm}$ (水平安装)
Fixing hole size	$\Phi 4.15\text{mm}$ (母排安装)
紧固螺丝	
Fastening steel screw	M4
建议紧固扭矩	
Recommended fastening torque	2.2Nm($\pm 10\%$)
连接器	
Connection of secondary	1565749-1

绝对最大额定参数（不操作） Absolute Maximum ratings (not operating)

除非另有说明，否则环境参数均为@ $T_A = 25\text{ }^\circ\text{C}$

最大正向允许供电电压 U_c Maximum positive supply voltage	+7V
最大反向允许供电电压 U_c Maximum reverse supply voltage	-0.3V
最大正向输出电压 V_{out} Maximum positive output voltage	+5.5V
最大反向输出电压 V_{out} Maximum reverse output voltage	-0.3V
输出短路持续时间 t_c Output Short circuit duration	2minutes
静电放电抗扰度（HBM） U_{ESD} Electrostatic discharge voltage（HBM）	2KV
输出钳位电压最小 V_{SZ} Output clamping voltage minimum	0.1V
输出钳位电压最大值 V_{SZ} Output clamping voltage maximum	4.9V
磁偏置电流 I_{OM} Magnetic offset current	$\leq \pm 0.9A$
绝缘电阻 R_{IS} Insulation resistance	$\geq 500M\ \Omega$
工作环境温度 T_A Ambient operating temperature	-40~+125 $^\circ\text{C}$
储存环境温度 T_S Ambient storage temperature	-40~+125 $^\circ\text{C}$
频带宽度 BW Frequency bandwidth-3db	DC~100KHz
平均温度系数 V_{OE} Average temperature coefficient of	$\pm 0.08mV/^\circ\text{C}$
平均温度系数 G Average temperature coefficient of	$\pm 0.035\%/^\circ\text{C}$

测量电流计算公式 Measurement of current calculation formula

$$I_P = (V_{OUT} - U_C/2) \times (1/G)$$

电气参数 Electrical data AHKC-HAB 100

除非另有说明，否则环境参数均为@ $T_A = 25^\circ\text{C}$

型号 Type	AHKC-HAB 100
额定测量电流 I_P Rated input	$\pm 100\text{A}$
测量范围 I_{PM} Measure range	$\pm 110\text{A}$
电源电压 U_C Supply voltage	+5VDC ($\pm 5\%$)
零点失调电压 V_O Offset voltage	$1/2U_C$
灵敏度 G Sensitivity	20mV/A
额定输出电压 V_{OUT} Rated output voltage	$2.5 \pm 2\text{V}$
输出电压分辨率 Output resolution	2.5mV
负载电阻 R_L Load resistance	10K Ω
灵敏度误差 ϵ_G Sensitivity error	$\pm 1\%$
零点失调电压偏置 V_{OE} Electrical offset voltage	$\pm 5\text{mV}$
剩磁 V_{OM} Magnetic offset voltage	$\pm 3\text{mV}$
零点失调电压温漂 TCV_{OEAV} Average temperature coefficient of V_{OE}	$\pm 0.06\text{mV}/^\circ\text{C}$
灵敏度电压温漂 TCG_{AV} Average temperature coefficient of G	$\pm 0.02\%/^\circ\text{C}$
线性度 ϵ_L Linearity	$\leq 0.5\%FS$
静态电流消耗 I_C Current consumption	$\leq 15\text{mA}$
响应时间 T_R Response time	$< 5\mu\text{s}$
质量 m Mass	$\approx 80\text{g}$
执行标准 Standards	SJ 20790-2000; JB/T 7490-2007

电气参数 Electrical data AHKC-HAB 200

除非另有说明，否则环境参数均为@ $T_A = 25^\circ\text{C}$

型号 Type	AHKC-HAB 200
额定测量电流 I_P Rated input	$\pm 200\text{A}$
测量范围 I_{PM} Measure range	$\pm 220\text{A}$
电源电压 U_C Supply voltage	+5VDC ($\pm 5\%$)
零点失调电压 V_O Offset voltage	$1/2U_C$
灵敏度 G Sensitivity	10mV/A
额定输出电压 V_{OUT} Rated output voltage	$2.5 \pm 2\text{V}$
输出电压分辨率 Output resolution	2.5mV
负载电阻 R_L Load resistance	10K Ω
灵敏度误差 ε_G Sensitivity error	$\pm 1\%$
零点失调电压偏置 V_{OE} Electrical offset voltage	$\pm 5\text{mV}$
剩磁 V_{OM} Magnetic offset voltage	$\pm 3\text{mV}$
零点失调电压温漂 TCV_{OEAV} Average temperature coefficient of V_{OE}	$\pm 0.06\text{mV}/^\circ\text{C}$
灵敏度电压温漂 TCG_{AV} Average temperature coefficient of G	$\pm 0.02\%/^\circ\text{C}$
线性度 ε_L Linearity	$\leq 0.5\%FS$
静态电流消耗 I_C Current consumption	$\leq 15\text{mA}$
响应时间 T_R Response time	$< 5\mu\text{s}$
质量 m Mass	$\approx 80\text{g}$
执行标准 Standards	SJ 20790-2000; JB/T 7490-2007

电气参数 Electrical data AHKC-HAB 300

除非另有说明，否则环境参数均为@ $T_A = 25^\circ\text{C}$

型号 Type	AHKC-HAB-300
额定测量电流 I_P Rated input	$\pm 300\text{A}$
测量范围 I_{PM} Measure range	$\pm 330\text{A}$
电源电压 U_C Supply voltage	+5VDC ($\pm 5\%$)
零点失调电压 V_O Offset voltage	$1/2U_C$
灵敏度 G Sensitivity	6.667mV/A
额定输出电压 V_{OUT} Rated output voltage	$2.5 \pm 2\text{V}$
输出电压分辨率 Output resolution	2.5mV
负载电阻 R_L Load resistance	10K Ω
灵敏度误差 ϵ_G Sensitivity error	$\pm 1\%$
零点失调电压偏置 V_{OE} Electrical offset voltage	$\pm 5\text{mV}$
剩磁 V_{OM} Magnetic offset voltage	$\pm 3\text{mV}$
零点失调电压温漂 TCV_{OEAV} Average temperature coefficient of V_{OE}	$\pm 0.06\text{mV}/^\circ\text{C}$
灵敏度电压温漂 TCG_{AV} Average temperature coefficient of G	$\pm 0.02\%/^\circ\text{C}$
线性度 ϵ_L Linearity	$\leq 0.5\%FS$
静态电流消耗 I_C Current consumption	$\leq 15\text{mA}$
响应时间 T_R Response time	$< 5\mu\text{s}$
质量 m Mass	$\approx 80\text{g}$
执行标准 Standards	SJ 20790-2000; JB/T 7490-2007

电气参数 Electrical data AHKC-HAB 400

除非另有说明，否则环境参数均为@ $T_A = 25^\circ\text{C}$

型号 Type	AHKC-HAB 400
额定测量电流 I_P Rated input	$\pm 400\text{A}$
测量范围 I_{PM} Measure range	$\pm 440\text{A}$
电源电压 U_C Supply voltage	+5VDC ($\pm 5\%$)
零点失调电压 V_O Offset voltage	$1/2U_C$
灵敏度 G Sensitivity	5mV/A
额定输出电压 V_{OUT} Rated output voltage	$2.5 \pm 2\text{V}$
输出电压分辨率 Output resolution	2.5mV
负载电阻 R_L Load resistance	10K Ω
灵敏度误差 ϵ_G Sensitivity error	$\pm 1\%$
零点失调电压偏置 V_{OE} Electrical offset voltage	$\pm 5\text{mV}$
剩磁 V_{OM} Magnetic offset voltage	$\pm 3\text{mV}$
零点失调电压温漂 TCV_{OEAV} Average temperature coefficient of V_{OE}	$\pm 0.06\text{mV}/^\circ\text{C}$
灵敏度电压温漂 TCG_{AV} Average temperature coefficient of G	$\pm 0.02\%/^\circ\text{C}$
线性度 ϵ_L Linearity	$\leq 0.5\%FS$
静态电流消耗 I_C Current consumption	$\leq 15\text{mA}$
响应时间 T_R Response time	$< 5\mu\text{s}$
质量 m Mass	$\approx 80\text{g}$
执行标准 Standards	SJ 20790-2000; JB/T 7490-2007

电气参数 Electrical data AHKC-HAB

除非另有说明，否则环境参数均为@ $T_A = 25^\circ\text{C}$

型号 Type	AHKC-HAB
额定测量电流 I_P Rated input	$\pm 500\text{A}$
测量范围 I_{PM} Measure range	$\pm 550\text{A}$
电源电压 U_C Supply voltage	+5VDC ($\pm 5\%$)
零点失调电压 V_O Offset voltage	$1/2U_C$
灵敏度 G Sensitivity	4mV/A
额定输出电压 V_{OUT} Rated output voltage	$2.5 \pm 2\text{V}$
输出电压分辨率 Output resolution	2.5mV
负载电阻 R_L Load resistance	10K Ω
灵敏度误差 ε_G Sensitivity error	$\pm 1\%$
零点失调电压偏置 V_{OE} Electrical offset voltage	$\pm 5\text{mV}$
剩磁 V_{OM} Magnetic offset voltage	$\pm 3\text{mV}$
零点失调电压温漂 TCV_{OEAV} Average temperature coefficient of V_{OE}	$\pm 0.06\text{mV}/^\circ\text{C}$
灵敏度电压温漂 TCG_{AV} Average temperature coefficient of G	$\pm 0.02\%/^\circ\text{C}$
线性度 ε_L Linearity	$\leq 0.5\%FS$
静态电流消耗 I_C Current consumption	$\leq 15\text{mA}$
响应时间 T_R Response time	$< 5\mu\text{s}$
质量 m Mass	$\approx 80\text{g}$
执行标准 Standards	SJ 20790-2000; JB/T 7490-2007

电气参数 Electrical data AHKC-HAB

除非另有说明，否则环境参数均为@ $T_A = 25^\circ\text{C}$

型号 Type	AHKC-HAB
额定测量电流 I_P Rated input	$\pm 600\text{A}$
测量范围 I_{PM} Measure range	$\pm 660\text{A}$
电源电压 U_C Supply voltage	+5VDC ($\pm 5\%$)
零点失调电压 V_O Offset voltage	$1/2U_C$
灵敏度 G Sensitivity	3.333mV/A
额定输出电压 V_{OUT} Rated output voltage	$2.5 \pm 2\text{V}$
输出电压分辨率 Output resolution	2.5mV
负载电阻 R_L Load resistance	10K Ω
灵敏度误差 ε_G Sensitivity error	$\pm 1\%$
零点失调电压偏置 V_{OE} Electrical offset voltage	$\pm 5\text{mV}$
剩磁 V_{OM} Magnetic offset voltage	$\pm 3\text{mV}$
零点失调电压温漂 TCV_{OEAV} Average temperature coefficient of V_{OE}	$\pm 0.06\text{mV}/^\circ\text{C}$
灵敏度电压温漂 TCG_{AV} Average temperature coefficient of G	$\pm 0.02\%/^\circ\text{C}$
线性度 ε_L Linearity	$\leq 0.5\%FS$
静态电流消耗 I_C Current consumption	$\leq 15\text{mA}$
响应时间 T_R Response time	$< 5\mu\text{s}$
质量 m Mass	$\approx 80\text{g}$
执行标准 Standards	SJ 20790-2000; JB/T 7490-2007

电气参数 Electrical data AHKC-HAB

除非另有说明，否则环境参数均为@ $T_A = 25^\circ\text{C}$

型号 Type	AHKC-HAB
额定测量电流 I_P Rated input	$\pm 700\text{A}$
测量范围 I_{PM} Measure range	$\pm 770\text{A}$
电源电压 U_C Supply voltage	+5VDC ($\pm 5\%$)
零点失调电压 V_O Offset voltage	$1/2U_C$
灵敏度 G Sensitivity	2.857mV/A
额定输出电压 V_{OUT} Rated output voltage	$2.5 \pm 2\text{V}$
输出电压分辨率 Output resolution	2.5mV
负载电阻 R_L Load resistance	10K Ω
灵敏度误差 ε_G Sensitivity error	$\pm 1\%$
零点失调电压偏置 V_{OE} Electrical offset voltage	$\pm 5\text{mV}$
剩磁 V_{OM} Magnetic offset voltage	$\pm 3\text{mV}$
零点失调电压温漂 TCV_{OEAV} Average temperature coefficient of V_{OE}	$\pm 0.06\text{mV}/^\circ\text{C}$
灵敏度电压温漂 TCG_{AV} Average temperature coefficient of G	$\pm 0.02\%/^\circ\text{C}$
线性度 ε_L Linearity	$\leq 0.5\%FS$
静态电流消耗 I_C Current consumption	$\leq 15\text{mA}$
响应时间 T_R Response time	$< 5\mu\text{s}$
质量 m Mass	$\approx 80\text{g}$
执行标准 Standards	SJ 20790-2000; JB/T 7490-2007

电气参数 Electrical data AHKC-HAB

除非另有说明，否则环境参数均为@ $T_A = 25\text{ }^\circ\text{C}$

型号 Type	AHKC-HAB
额定测量电流 I_P Rated input	$\pm 800\text{A}$
测量范围 I_{PM} Measure range	$\pm 880\text{A}$
电源电压 U_C Supply voltage	+5VDC ($\pm 5\%$)
零点失调电压 V_O Offset voltage	$1/2U_C$
灵敏度 G Sensitivity	2.5mV/A
额定输出电压 V_{OUT} Rated output voltage	$2.5 \pm 2\text{V}$
输出电压分辨率 Output resolution	2.5mV
负载电阻 R_L Load resistance	10K Ω
灵敏度误差 ε_G Sensitivity error	$\pm 1\%$
零点失调电压偏置 V_{OE} Electrical offset voltage	$\pm 5\text{mV}$
剩磁 V_{OM} Magnetic offset voltage	$\pm 3\text{mV}$
零点失调电压温漂 TCV_{OEAV} Average temperature coefficient of V_{OE}	$\pm 0.06\text{mV}/^\circ\text{C}$
灵敏度电压温漂 TCG_{AV} Average temperature coefficient of G	$\pm 0.02\%/^\circ\text{C}$
线性度 ε_L Linearity	$\leq 0.5\%FS$
静态电流消耗 I_C Current consumption	$\leq 15\text{mA}$
响应时间 T_R Response time	$< 5\mu\text{s}$
质量 m Mass	$\approx 80\text{g}$
执行标准 Standards	SJ 20790-2000; JB/T 7490-2007

电气参数 Electrical data AHKC-HAB

除非另有说明，否则环境参数均为@ $T_A = 25^\circ\text{C}$

型号 Type	AHKC-HAB
额定测量电流 I_P Rated input	$\pm 900\text{A}$
测量范围 I_{PM} Measure range	$\pm 990\text{A}$
电源电压 U_C Supply voltage	+5VDC ($\pm 5\%$)
零点失调电压 V_O Offset voltage	$1/2U_C$
灵敏度 G Sensitivity	2.222mV/A
额定输出电压 V_{OUT} Rated output voltage	$2.5 \pm 2\text{V}$
输出电压分辨率 Output resolution	2.5mV
负载电阻 R_L Load resistance	10K Ω
灵敏度误差 ε_G Sensitivity error	$\pm 1\%$
零点失调电压偏置 V_{OE} Electrical offset voltage	$\pm 5\text{mV}$
剩磁 V_{OM} Magnetic offset voltage	$\pm 3\text{mV}$
零点失调电压温漂 TCV_{OEAV} Average temperature coefficient of V_{OE}	$\pm 0.06\text{mV}/^\circ\text{C}$
灵敏度电压温漂 TCG_{AV} Average temperature coefficient of G	$\pm 0.02\%/^\circ\text{C}$
线性度 ε_L Linearity	$\leq 0.5\%FS$
静态电流消耗 I_C Current consumption	$\leq 15\text{mA}$
响应时间 T_R Response time	$< 5\mu\text{s}$
质量 m Mass	$\approx 80\text{g}$
执行标准 Standards	SJ 20790-2000; JB/T 7490-2007